

## V4297S Normally Open Vent Valve

### PRODUCT DATA

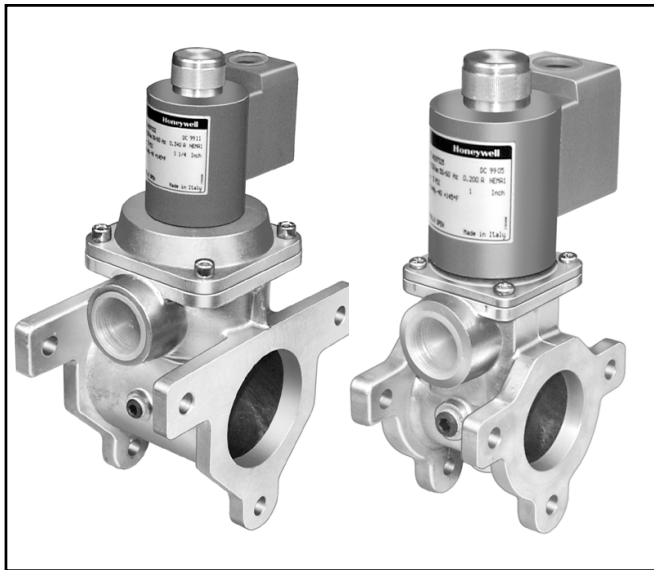

### FEATURES

- Used with natural, manufactured, mixed or liquefied petroleum (LP) gases.
- V4297S valves are normally open valves to be used as vent valves in double block and bleed configurations. The gas flows through the vent connection when the valve is not energized.
- V4297S are used with 110/120Vac 50/60Hz controllers.
- Two valve body types (small and large) applicable to seven pipe sizes:
  - Small body type for 3/4 in. (19 mm), 1 in. (25 mm), 1-1/4 in. (32 mm), 1-1/2 in. (38 mm) and 2 in. (51 mm) pipes.
  - Large body type for 2 in. (51 mm), 2-1/2 in. (64 mm) and 3 in. (76 mm) pipes.
- Small body has a 1 in. NPT threaded vent connection. Large body has a 1-1/4 in. NPT threaded vent connection.
- Two 1/4 in. NPT threaded pressure taps available for the small body valve, three for the large body valve.
- NEMA 1 enclosure standard.
- V4297S is not gas flow direction dependent. It can be connected either way in the valve train.
- Unpainted die-cast aluminum body.

### APPLICATION

The V4297S provides the vent function in a double block and bleed configuration. The valve is part of the Honeywell Integrated Valve Train System, which allows gas train components to be directly bolted together.



## SPECIFICATIONS

### IMPORTANT

*The specifications in this publication do not include normal manufacturing tolerances; therefore, an individual unit may not exactly match the specifications listed. Also, this product is tested and calibrated under closely controlled conditions, and some minor differences in performance can be expected if those conditions are changed.*

### Models:

V4297S Normally Open Vent Valve.

### Type of Gas:

Natural, manufactured, mixed or liquefied petroleum (LP) only.

### Gas Train Pipe Size:

3/4 in. (19 mm), 1 in. (25 mm), 1-1/4 in. (32 mm),  
1-1/2 in. (38 mm), 2 in. (51 mm), 2-1/2 in. (64 mm),  
3 in. (76 mm).

### Pipe Threads:

Small Body: 1 in. NPT threaded vent connection.  
Large Body: 1-1/4 in. NPT threaded vent connection.

### Operating Pressure Rating:

Maximum: 5 psi.

### Valve Capacity through Vent Connection:

Ratings: 1 in. (0.25 kPa) pressure drop for gas with 0.64 sp gr.  
Small Body: 714 cfh.  
Large Body: 1115 cfh.

### Bolt/Nut Fasteners:

Bolts, nuts and O-rings are provided with the safety shutoff valves.

### Tapping and plug:

Taps: 1/4 in. NPT taps.  
Plugs: Allen head.

### Ambient Operating Temperature Rating:

-40°F to +145°F (-40°C to +63°C).

### Material:

Die-cast aluminum.

### Mounting:

Bolted to Integrated Valve Train components.

### Mounting Position:

Vertical to 90 degrees from vertical. See Fig. 1.

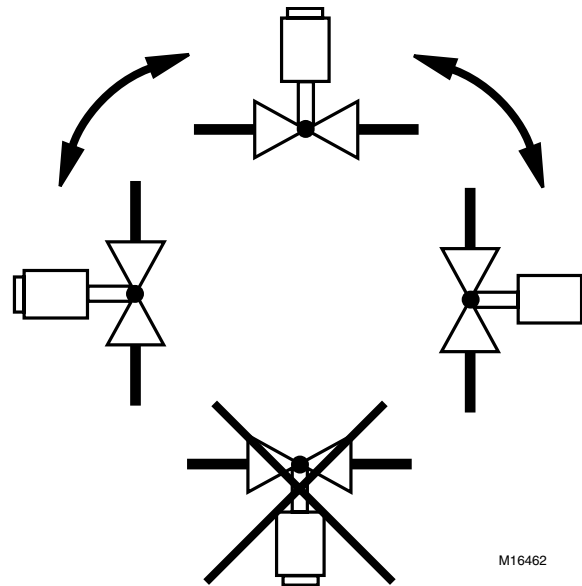

**Fig. 1. Mounting positions for V4297S Normally Open Vent Valve.**

### Electrical Terminations:

Screw terminal connections.

### Current Draw:

V4297S small body, 120V: 0.2A.  
V4297S large body, 120V: 0.34A.

### Valve opening time: < 1 sec.

### Valve closing time: < 1 sec.

### Dimensions:

See Fig. 2 and 3.

## ORDERING INFORMATION

When purchasing replacement and modernization products from your TRADELINE® wholesaler or distributor, refer to the TRADELINE® Catalog or price sheets for complete ordering number.

If you have additional questions, need further information, or would like to comment on our products or services, please write or phone:

1. Your local Home and Building Control Sales Office (check white pages of your phone directory).
2. Home and Building Control Customer Logistics  
Honeywell Inc., 1985 Douglas Drive North  
Minneapolis, Minnesota 55422-4386

In Canada—Honeywell Limited/Honeywell Limitée, 35 Dynamic Drive, Scarborough, Ontario M1V 4Z9.  
International Sales and Service Offices in all principal cities of the world. Manufacturing in Australia, Canada, Finland, France, Germany, Japan, Mexico, Netherlands, Spain, Taiwan, United Kingdom, U.S.A.

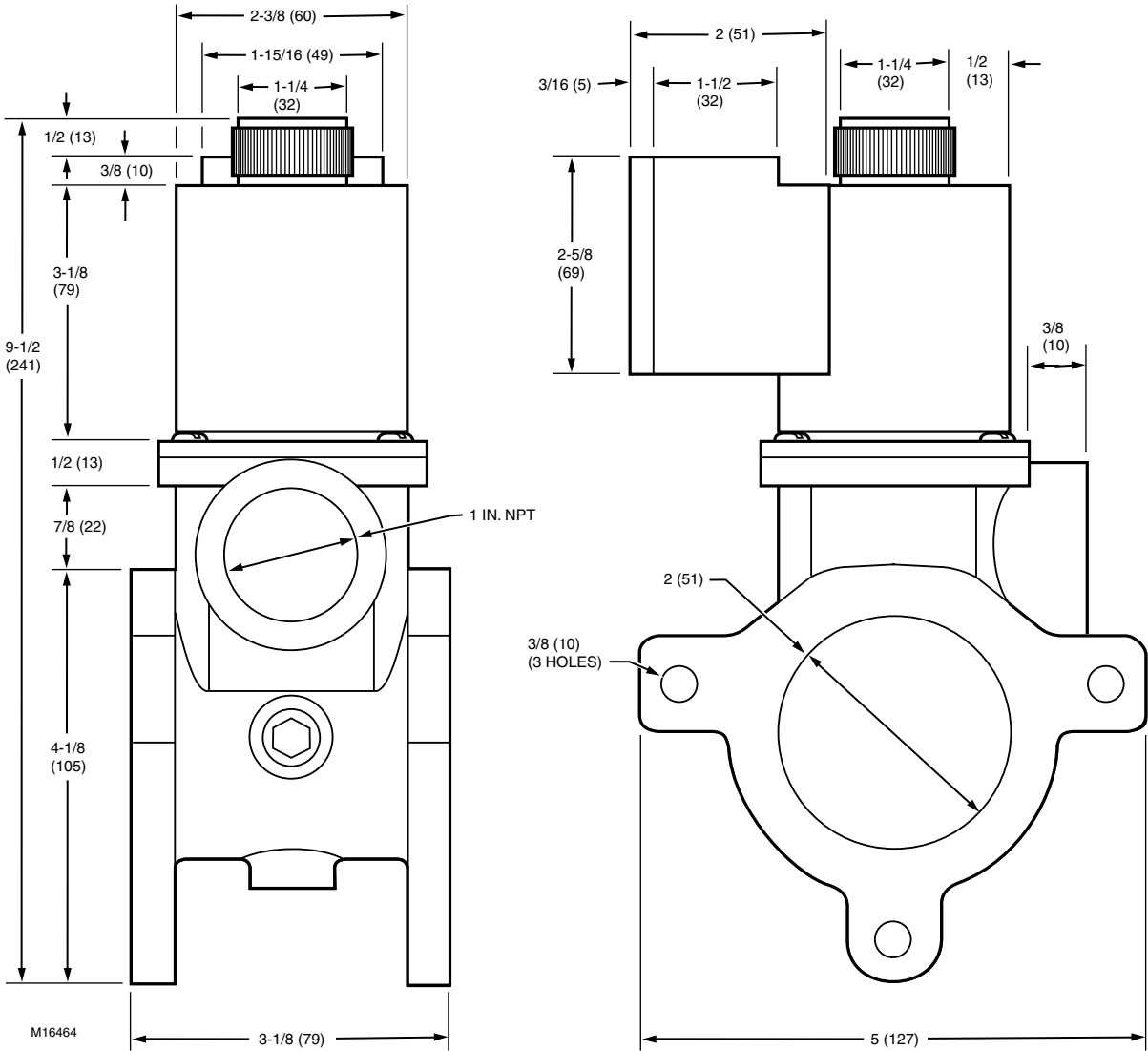

Fig. 2. Approximate dimensions of smaller V4297 NOV in in. (mm).

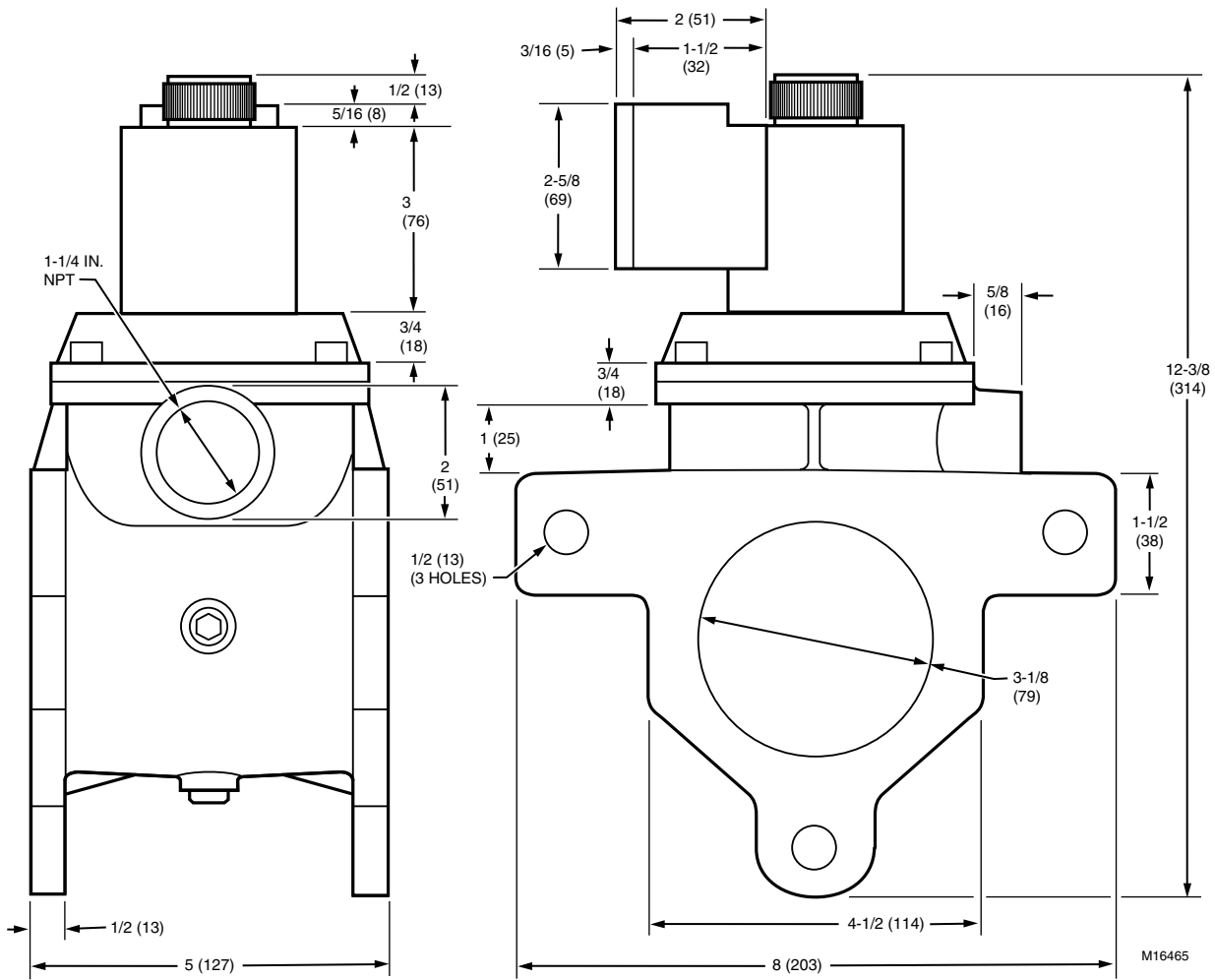

Fig. 3. Approximate dimensions of larger V4297 NOVV in in. (mm).

**Weight:**

V4297S small body: 5.5 lb (2.5 kg).  
 V4297S large body: 9.5 lb (4.4 kg).

**Replacement Parts:**

BBA51316 Coil for small V4297S, complete with wiring box.  
 BBA51317 Coil for large V4297S, complete with wiring box.

**Approvals:**

Underwriters Laboratories Inc.: Listed.  
 Industrial Risk Insurers (formerly FIA): Acceptable.  
 International Approval Services (IAS): Design Certified.

## INSTALLATION

### When Installing this product...

1. Read these instructions carefully. Be sure to follow Warning information carefully.
2. Check the ratings given in the instructions and on the product to make sure the product is suitable for your application.
3. Installer must be a trained, experienced flame safeguard control technician.
4. After installation is complete, check out product operation as provided in these instructions.

### **⚠️ WARNING**

**Explosion Hazard And Electrical Shock Hazard. Can cause explosion, serious injury or death.**  
Turn off gas supply before starting installation.  
Disconnect power supply before beginning installation.  
More than one disconnection can be involved.

### Mounting

Refer to the Integrated Valve Train Installation Instructions, form 66-1099, for instructions on mounting a V4297S between two Safety Shutoff valves.

## WIRING

1. Make sure that all wiring agrees with all applicable local codes, ordinances and regulations. An opening is provided to accommodate rigid conduit or armored cable for line voltage operation (see Fig. 4).



Fig. 4. Wiring compartment of V4297 NOV.

2. Check the power supply circuit to verify the voltage and frequency are the same as for the valve.
3. See Fig. 5 for typical V4297S field wiring with the RM7800 Relay Module. Follow the burner manufacturer wiring diagram, when provided. Refer to the relay module wiring diagram for specific wiring terminal designations.
4. Make wiring connections at the electrical terminations provided in the valve wiring compartment.

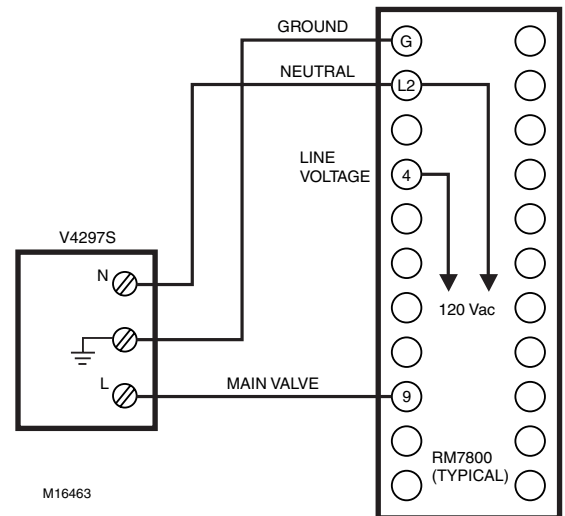

Fig. 5. Typical wiring diagram for V4297 NOV.

## OPERATION AND CHECKOUT

### Operation

The V4297S is a normally open valve. The valve closes when it is energized, and opens when the power is removed. It provides the vent function in a double block and bleed application. The V4297S is open when the two Safety Shutoff Valves (SSOV) are closed, and is closed when the two SSOV are open.

### Checkout

### **⚠️ WARNING**

**Explosion Hazard And Electrical Shock Hazard. Can cause explosion, serious injury or death.**

1. Do not put the system into service until you have satisfactorily completed the following Valve Leak Test, all applicable tests described in the Checkout section of the instructions for the flame safeguard control, and any other tests required by the burner manufacturer.
2. All tests must be performed by a trained, experienced, flame safeguard control technician.
3. Close all manual fuel shutoff valves as soon as trouble occurs.

After the installation is completed, cycle the valve several times with the manual fuel shutoff cock closed. Make sure the valve functions properly. Also perform the Valve Leak Test before putting the valve into service.

## Valve Leak Test

This is a test for checking the closure tightness of the gas valve. It should be performed only by trained, experienced, flame safeguard control technicians during the initial startup of the burner system, or whenever the valve is replaced.

1. Energize the V4297S to close the vent connection.
2. Close the manual gas cock downstream of the second Safety Shutoff Valve (SSOV).
3. Turn on main gas and make sure the gas reaches the V4297S (energize the first SSOV).
4. Check the V4297S for gas leaks using a gas leak detector or a soap solution.

## TROUBLESHOOTING

### **WARNING**

**Electrical Shock Hazard.**

**Can cause serious injury or death.**

Use extreme caution while troubleshooting; line voltage is present.

### **IMPORTANT**

*Do not replace the valve until all other sources of trouble are eliminated.*

## Troubleshooting Procedure

If the valve does not close when the thermostat or controller is calling for heat:

1. Check for line voltage at the valve lead wires or terminal block.
2. If there is no voltage at the valve lead wires or terminal block, make sure:
  - a. line voltage power is connected to the master switch;
  - b. master switch is closed and overload protection (circuit breaker, fuse or similar device) has not opened the power line.
3. If there is still no voltage at the valve lead wires or terminal block, make sure all appropriate contacts in the thermostat or controller, limits and flame safeguard controls are closed. If one or more are open, determine the cause(s); correct the trouble, and proceed.
4. If there is proper voltage at the valve but the valve still does not close, check for normal gas pressure.
5. If the valve still does not close, replace the valve.

If the valve does not open when one or more of the appropriate contacts in the thermostat, controller, limits or flame safeguard control is open:

1. Make sure the valve is wired in the correct circuit.
2. Open the master switch to remove power from the valve.
3. If the valve opens now, check the wiring for the valve and correct the wiring as necessary.
4. Check for a short in the electrical circuit and repair it as necessary.

## SERVICE INFORMATION

### **WARNING**

**Explosion and Electrical Shock Hazard.**

**Can cause explosion, serious injury or death.**

1. Turn off the gas supply and disconnect all electrical power to the valve before servicing.

### **IMPORTANT**

*Only trained, experienced flame safeguard control technicians should attempt to service or repair flame safeguard controls and burner assemblies.*

## Scheduled Inspection and Maintenance

Set up and follow a schedule for periodic inspection and maintenance, including the burner, all other controls, and the valve(s). It is recommended that the valve leak test in the Checkout section be included in this schedule. Refer to the instructions for the primary safety control(s) for more inspection and maintenance information.



**Home and Building Control**

Honeywell Inc.  
Honeywell Plaza  
P.O. Box 524  
Minneapolis MN 55408-0524

**Honeywell Latin American Region**

480 Sawgrass Corporate Parkway  
Suite 200  
Sunrise FL 33325

**Home and Building Control**

Honeywell Limited-Honeywell Limitée  
155 Gordon Baker Road  
North York, Ontario  
M2H 3N7

**Honeywell Europe S.A.**

3 Avenue du Bourget  
1140 Brussels  
Belgium

**Honeywell Asia Pacific Inc.**

Room 3213-3225  
Sun Hung Kai Centre  
No. 30 Harbour Road  
Wanchai  
Hong Kong

**Honeywell**

